



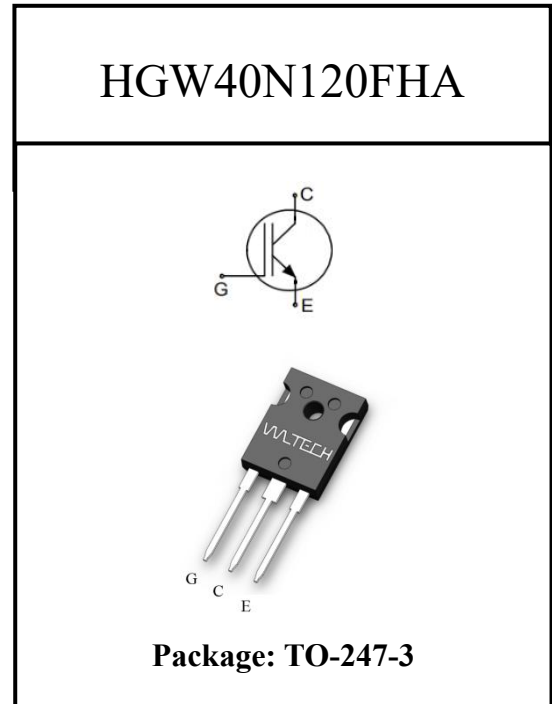
# High-speed IGBT Power Transistor

## 1. Product Features:

- Ultra-low switching losses
- Ultra-low static losses
- Maximum junction temperature 175°C
- Qualified according to JEDEC for target applications
- Pb-free lead plating;RoHS compliant

## 2. Product Applications

- Industrial Power Supplies
- Solar String Inverter
- Energy Storage Inverter
- UPS
- DC Charger for Electric Vehicles



## 3. Typical Performance Parameters

Tab.1. Typical Performance Parameters

Type	$V_{CE}$	$I_C$	$V_{CEsat}$ $T_{vj} = 25^\circ\text{C}$	$T_{vjmax}$	Marking	Package
HGW40N120FHA	1200V	40A	1.67V	175°C	HGW40N120FHA	TO-247-3

## 4. Maximum Ratings

**Tab.2. Maximum Ratings**

Parameters	Symbol	Value	Unit
Collector-emitter voltage	$V_{CE}$	1200	V
DC collector current (limited by $T_{vjmax}$ )	$I_C$	80.0 ( $T_c = 25^\circ\text{C}$ ) 40.0 ( $T_c = 100^\circ\text{C}$ )	A
Pulsed collector current ( $t_p$ limited by $T_{vjmax}$ .)	$I_{Cpuls}$	160.0	A
Turn off safe operating area ( $V_{CE} \leq 1200\text{V}$ , $T_{vj} \leq 175^\circ\text{C}$ )	-	160.0	A
Gate-emitter voltage	$V_{GE}$	$\pm 20$	V
Power dissipation	$P_{tot}$	441.0 ( $T_c = 25^\circ\text{C}$ ) 220.0 ( $T_c = 100^\circ\text{C}$ )	W
Operating junction temperature	$T_{vj}$	-40 to +175	$^\circ\text{C}$
Storage temperature	$T_{stg}$	-55 to +150	$^\circ\text{C}$
Soldering temperature, (wave soldering 1.6mm from case for 10s)		260	$^\circ\text{C}$
Mounting torque (M3 screw) (Maximum of mounting processes: 3)	$M$	0.6	Nm

## 5. Thermal Properties

**Tab.3. Thermal Properties**

Parameters	Symbol	Max. value	Unit
IGBT thermal resistance (junction - case)	$R_{th(j-c)}$	0.34	$^\circ\text{C/W}$
Thermal resistance (junction – ambient )	$R_{th(j-a)}$	40	$^\circ\text{C/W}$

## 6. Electrical Characteristics

**Tab.4. Static Characteristic ( $T_{vj} = 25^{\circ}\text{C}$ , unless otherwise specified)**

Parameters	Symbol	Conditions	Min. value	Typ. value	Max. value	Unit
Collector-emitter breakdown voltage	$V_{(BR)CES}$	$V_{GE} = 0\text{V}, I_C = 1\text{mA}$	1200	-	-	V
Collector-emitter saturation voltage	$V_{CEsat}$	$V_{GE} = 15\text{V}, I_C = 40\text{A}$ $T_{vj} = 25^{\circ}\text{C}$ $T_{vj} = 175^{\circ}\text{C}$	- -	1.67 2.52	2.4 -	V
Gate-emitter threshold voltage	$V_{GE(th)}$	$I_C = 1.00\text{mA}, V_{CE} = V_{GE}$	5.5	6.1	6.5	V
Zero gate voltage collector current	$I_{CES}$	$V_{CE} = 1200\text{V}, V_{GE} = 0\text{V}$ $T_{vj} = 25^{\circ}\text{C}$ $T_{vj} = 175^{\circ}\text{C}$	- -	- -	250 2500	$\mu\text{A}$
Gate-emitter leakage current	$I_{GES}$	$V_{CE} = 0\text{V}, V_{GE} = 20\text{V}$	-	-	200	nA
Transconductance	$g_{fs}$	$V_{CE} = 20\text{V}, I_C = 15.0\text{A}$	-	33.0	-	S

**Tab.5. Dynamic Characteristic ( $T_{vj} = 25^{\circ}\text{C}$ , unless otherwise specified)**

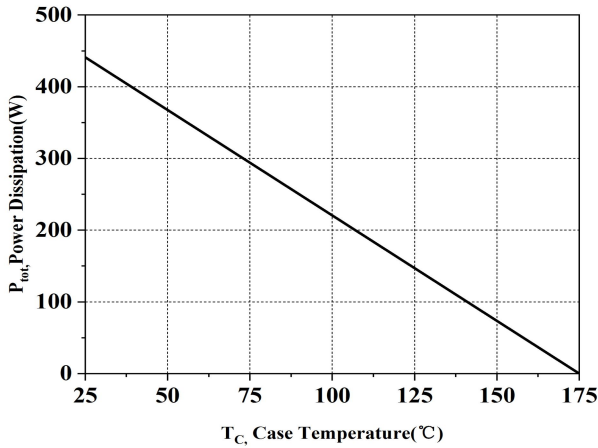
Parameters	Symbol	Conditions	Min. value	Typ. value	Max. value	Unit
Input capacitance	$C_{ies}$	$V_{CE} = 25\text{V}, V_{GE} = 0\text{V}$ $f = 1\text{MHz}$	-	9000	-	pF
Output capacitance	$C_{oes}$		-	154	-	
Reverse transfer capacitance	$C_{res}$		-	64	-	
Gate-charge	$Q_g$	$V_{CE} = 960\text{V}, I_C = 40.0\text{A},$ $V_{GE} = 15\text{V}$	-	307	-	nC

**Tab.6. Switching Characteristic (Inductive load)**

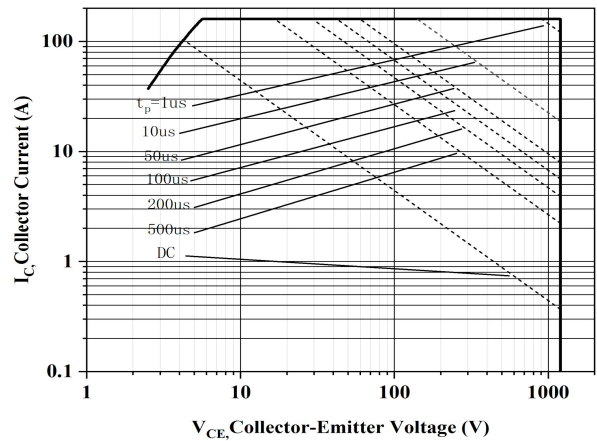
Parameters	Symbol	Conditions	Min. value	Typ. value	Max. value	Unit
IGBT Characteristic, at $T_{vj} = 25^{\circ}\text{C}$ , Driver SBD						
Turn-on delay time	$t_{d(on)}$	$T_{vj} = 25^{\circ}\text{C}$ , $V_{CC} = 600\text{V}$ , $I_C = 40.0\text{A}$ , $V_{GE} = 0.0/15.0\text{V}$ , $R_{G(on)} = R_{G(off)} = 12.0\Omega$ Inductive load	-	90	-	ns
Rise time	$t_r$		-	60	-	
Turn-off delay time	$t_{d(off)}$		-	362	-	
Fall time	$t_f$		-	100	-	
Turn-on energy	$E_{on}$	Energy losses include “tail” and diode reverse recovery.	-	1.55	-	mJ
Turn-off energy	$E_{off}$		-	1.68	-	
Total switching energy	$E_{ts}$		-	3.23	-	

**Tab.7. Switching Characteristic (Inductive load)**

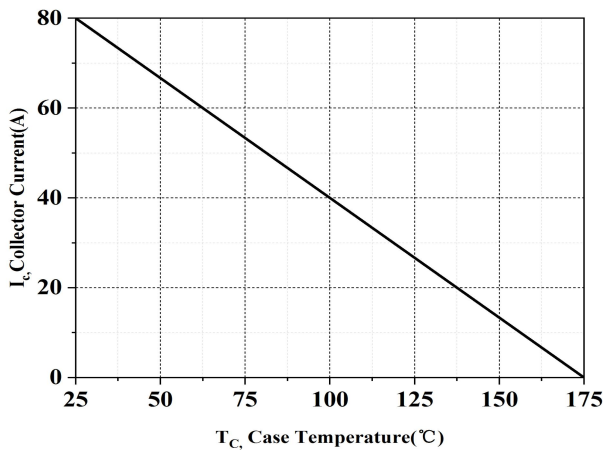
Parameters	Symbol	Conditions	Min. value	Typ. value	Max. value	Unit
IGBT Characteristic, at $T_{vj} = 175^{\circ}\text{C}$ , Driver SBD						
Turn-on delay time	$t_{d(on)}$	$T_{vj} = 175^{\circ}\text{C}$ , $V_{CC} = 600\text{V}$ , $I_C = 40.0\text{A}$ , $V_{GE} = 0.0/15.0\text{V}$ , $R_{G(on)} = R_{G(off)} = 12.0\Omega$ Inductive load	-	78	-	ns
Rise time	$t_r$		-	55	-	
Turn-off delay time	$t_{d(off)}$		-	413	-	
Fall time	$t_f$		-	123	-	
Turn-on energy	$E_{on}$	Energy losses include “tail” and diode reverse recovery.	-	1.73	-	mJ
Turn-off energy	$E_{off}$		-	2.12	-	
Total switching energy	$E_{ts}$		-	3.85	-	



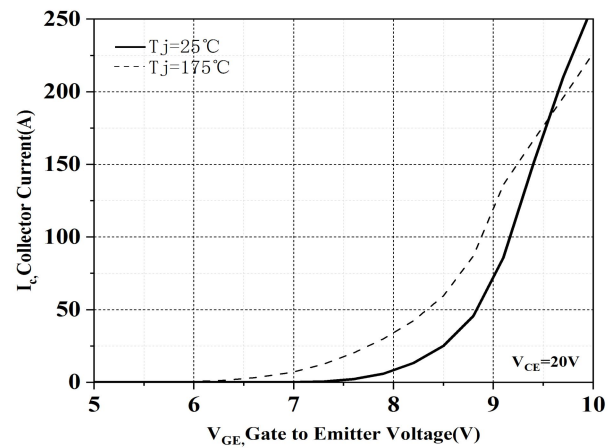
**Fig.1. Power dissipation as a function of case temperature ( $T_j \leq 175^\circ\text{C}$ )**



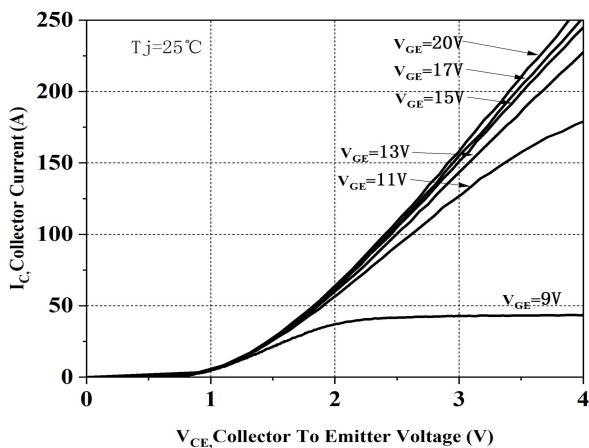
**Fig.2. Forward bias safe operating area ( $D = 0, T_C = 25^\circ\text{C}, T_j \leq 175^\circ\text{C}, V_{GE} = 15\text{V}$ )**



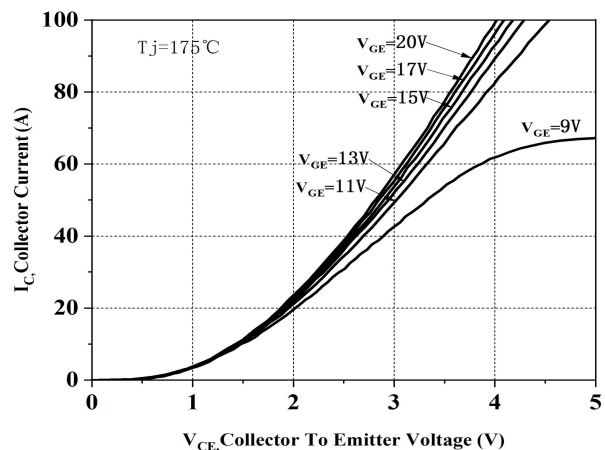
**Fig.3. Collector current as a function of case temperature ( $V_{GE} \geq 15\text{V}, T_j \leq 175^\circ\text{C}$ )**



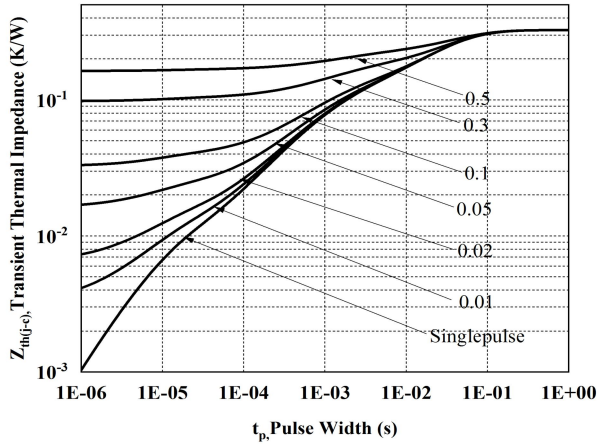
**Fig.4. Typical transfer characteristic**



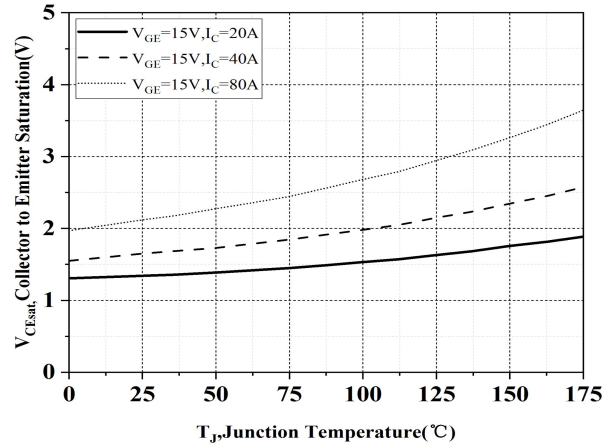
**Fig.5. Typical output characteristics ( $T_j = 25^\circ\text{C}$ )**



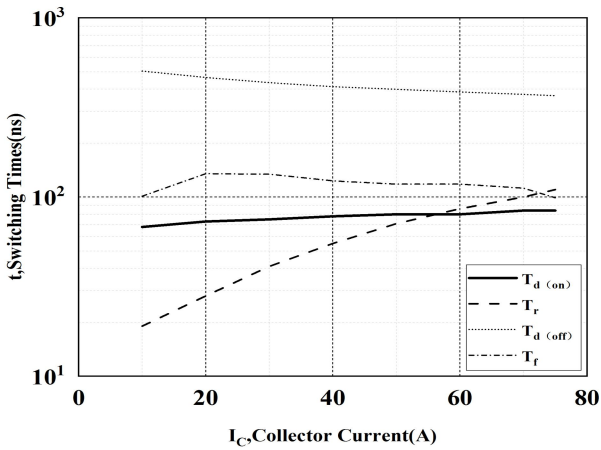
**Fig.6. Typical output characteristics ( $T_j = 175^\circ\text{C}$ )**



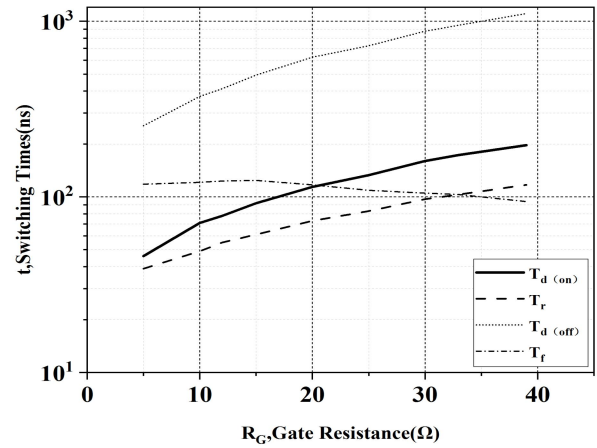
**Fig.7. IGBT transient thermal impedance**  
( $D = t_p/T$ )



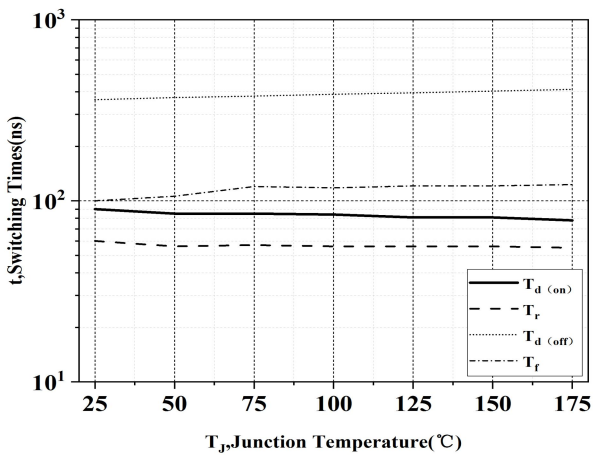
**Fig.8. Typical collector-emitter saturation voltage vs. junction temperature**



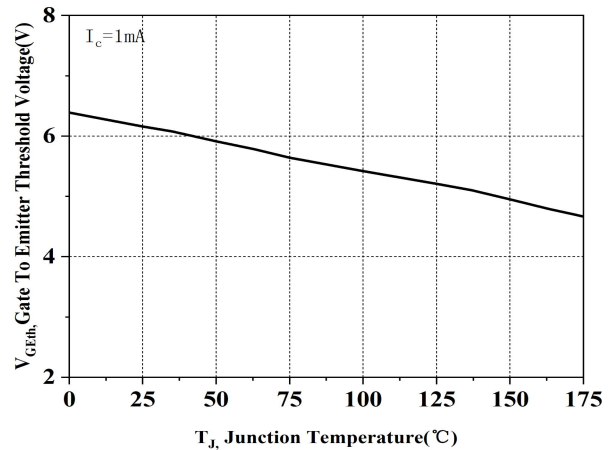
**Fig.9. Typical switching times vs. collector current**  
( $T_j = 175^\circ C, V_{CE} = 600V, V_{GE} = 15/0V$ )



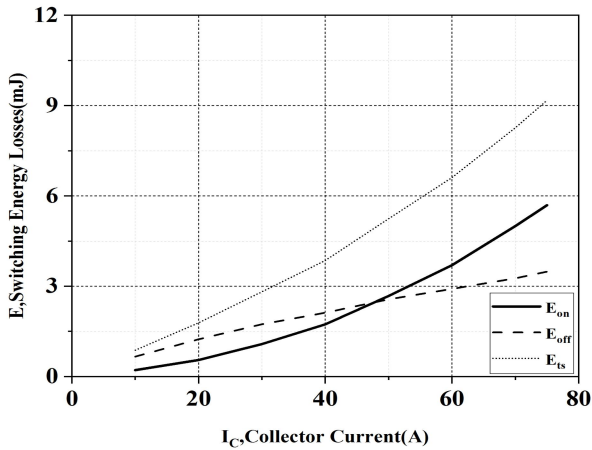
**Fig.10. Typical switching times vs. gate resistor**  
( $T_j = 175^\circ C, V_{CE} = 600V, V_{GE} = 15/0V, I_C = 40A$ )



**Fig.11. Typical switching times as a junction temperature**  
( $V_{CE} = 600V, V_{GE} = 15/0V, I_C = 40A$ )

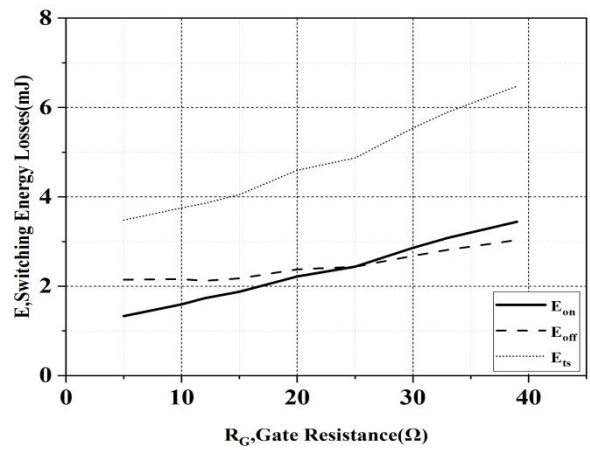


**Fig.12. Gate-emitter threshold voltage as a junction temperature**



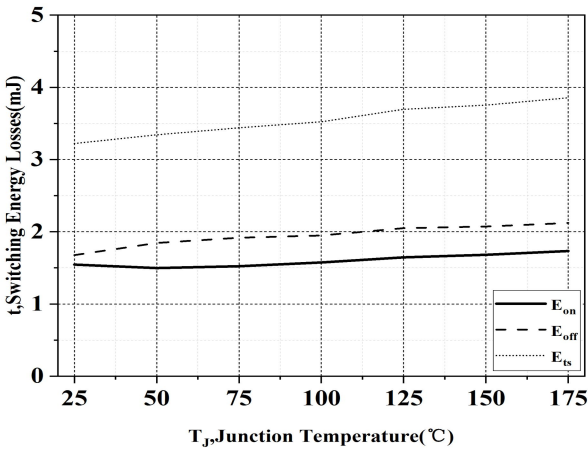
**Fig.13. Typical switching energy losses as a function of collector current**

( $T_j = 175^\circ\text{C}$ ,  $V_{CE} = 600\text{V}$ ,  $V_{GE} = 15/0\text{V}$ )



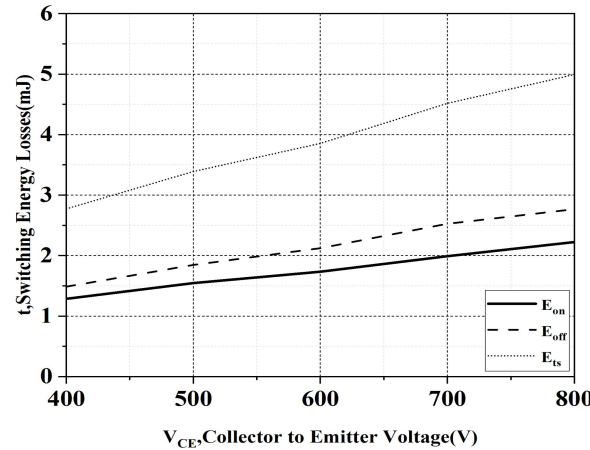
**Fig.14. Typical switching energy losses as a function of gate resistor**

( $T_j = 175^\circ\text{C}$ ,  $V_{CE} = 600\text{V}$ ,  $V_{GE} = 15/0\text{V}$ ,  $I_C = 40\text{A}$ )



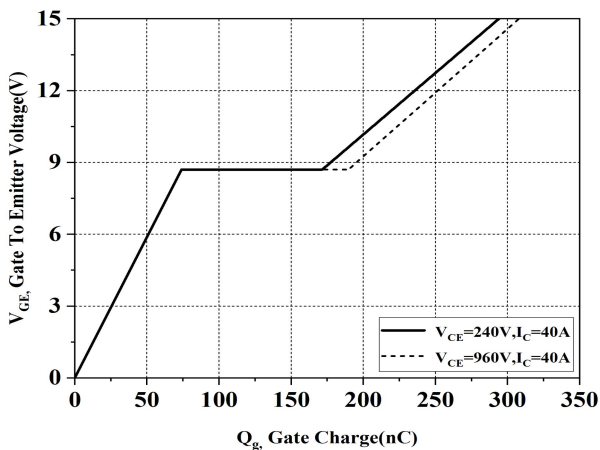
**Fig.15. Typical switching energy losses as a function of junction temperature**

(Inductive load,  $V_{CE} = 600\text{V}$ ,  $V_{GE} = 15/0\text{V}$ ,  $I_C = 40\text{A}$ )

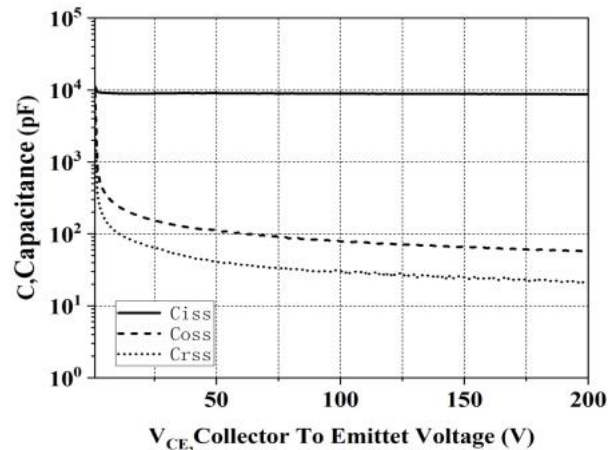


**Fig.16. Typical switching energy losses as a function of collector emitter voltage**

(Inductive load,  $T_j = 175^\circ\text{C}$ ,  $V_{GE} = 15/0\text{V}$ ,  $I_C = 40\text{A}$ )



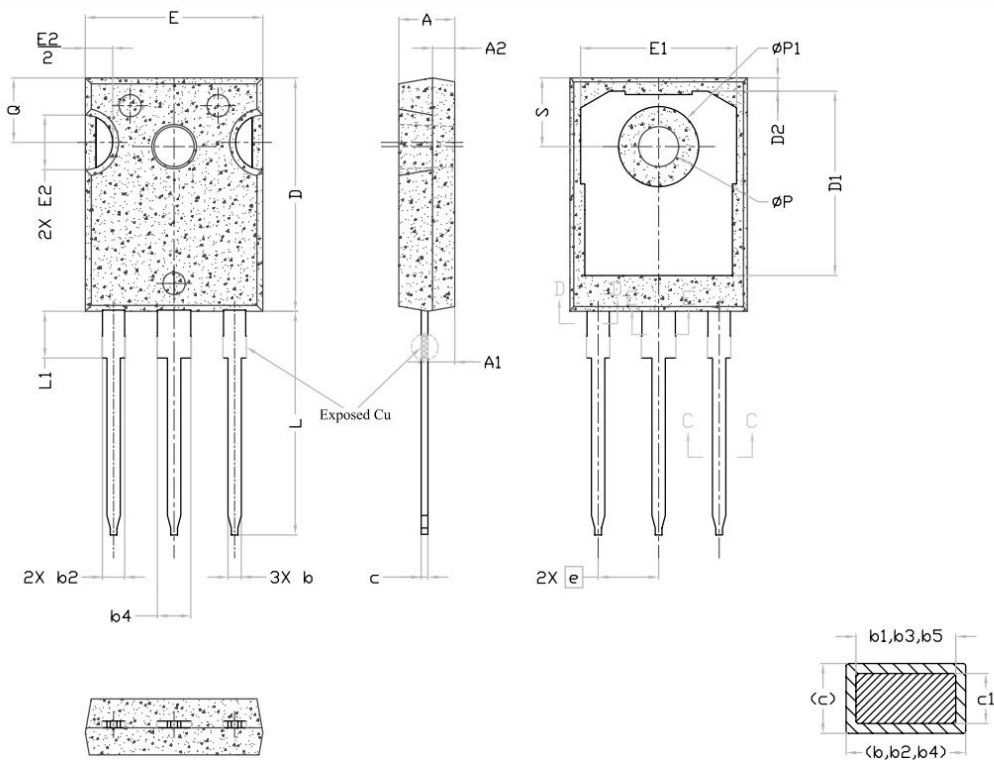
**Fig.17. Typical gate charge**



**Fig.18. Typical capacitance as a function of collector-emitter voltage**

( $V_{GE} = 0\text{V}$ ,  $f = 1\text{MHz}$ )

## 7. Package Dimensions



SYMBOL	DIMENSIONS			NOTES
	MIN.	NOM.	MAX.	
A	4.83	5.02	5.21	
A1	2.29	2.41	2.55	
A2	1.50	2.00	2.49	
b	1.12	1.20	1.33	
b1	1.12	1.20	1.28	
b2	1.91	2.00	2.39	6
b3	1.91	2.00	2.34	
b4	2.87	3.00	3.22	6, 8
b5	2.87	3.00	3.18	
c	0.55	0.60	0.69	6
c1	0.55	0.60	0.65	
D	20.80	20.95	21.10	4
D1	16.25	16.55	17.65	5
D2	0.51	1.19	1.35	
E	15.75	15.94	16.13	4
E1	13.46	14.02	14.16	5
E2	4.32	4.91	5.49	3
e	5.44BSC			
L	19.81	20.07	20.32	
L1	4.10	4.19	4.40	6
ØP	3.56	3.61	3.65	7
ØP1	7.19REF.			
Q	5.39	5.79	6.20	
S	6.04	6.17	6.30	



## 8. Version Information

Version No.	Status	Date changed	Version revision record
V1.0	Initial release	2022/09	